

A3/DLT TRAY KIT
(Machine Code: B331)

1. INSTALLATION

For details about installing the A3/DLT Kit B331, please refer to the instructions you received with the instructions or the “1. Installation” in the main machine service manual.

2. REPLACEMENT AND ADJUSTMENT

2.1 BOTTOM PLATE LIFT WIRE REPLACEMENT

NOTE: Before replacing the rear bottom plate lift wire, remove the front bottom plate lift wire. The procedure for the two wires is the same.

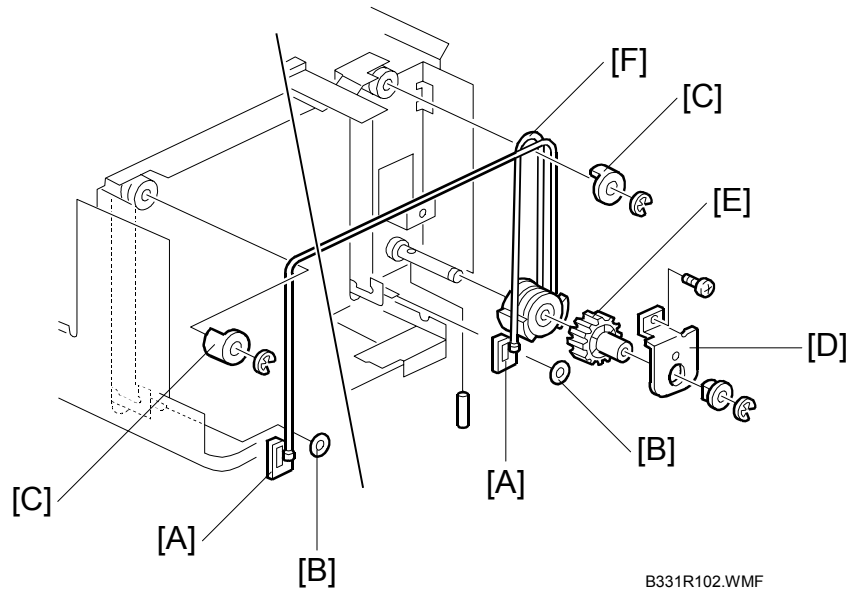

1. Remove the tray.
2. Remove the inner cover (2 screws).
3. Slightly lift the front bottom plate and unhook the wire stoppers [A] (2 stoppers [B]).
4. Remove the wire cover [C] (1 E-ring each).
5. Remove the bracket [D] (1 screw, 1 E-ring, and 1 bushing).
6. Remove the gear [E].
7. Replace the bottom plate lift wire [F].

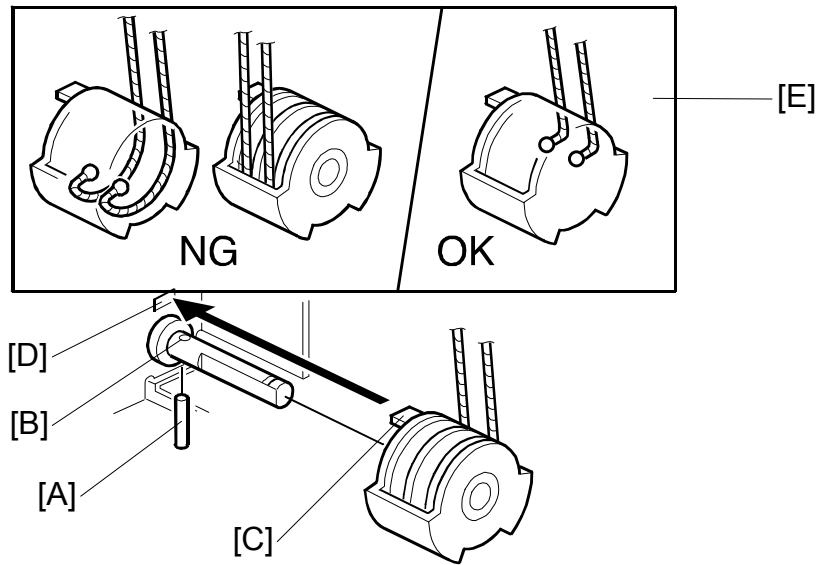

B331R061.WMF

NOTE: When re-installing the bottom plate lift wire:

- 1) Set the positioning pin [A] in the hole [B] and set the projection [C] in the hole [D].
- 2) Position the wire as shown [E].
- 3) Do not cross the wires.

3. DETAILED DESCRIPTIONS

3.1 SECTIONAL DESCRIPTION

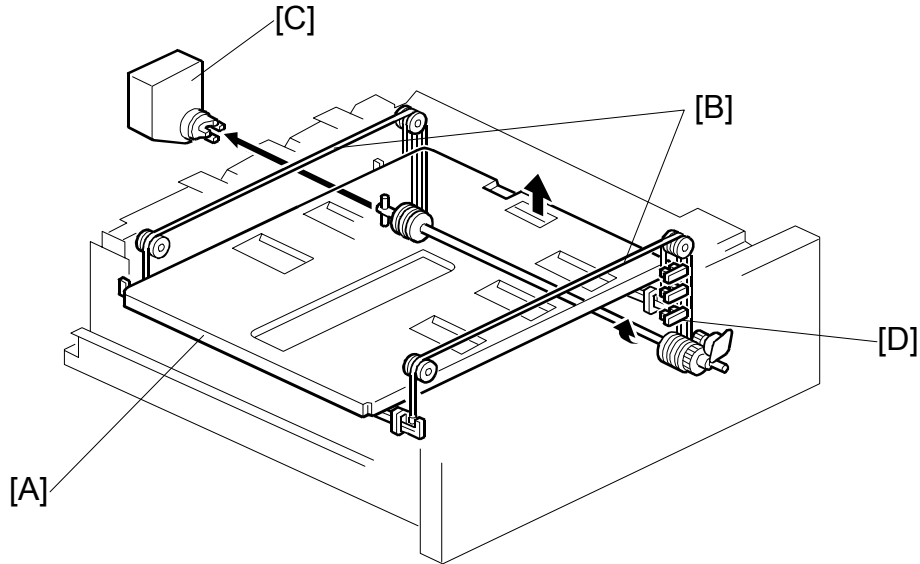

B331D201.WMF

This tray mechanism is basically same as the tandem LCT. This tray bottom plate [A] is lifted through the tray wires [B] by the lift motor [C] rotation. There is no remaining paper capacity detection.

The paper remaining sensors [D] trigger messages on the LCD to let the user know how much paper remains in the tray.

The operation panel LCD displays “full” whether there is paper in the tray. Except for the above matter, refer to the main copier tandem LCT section for details.